

Model	P/N	Minimum torque at rated current (Kg.cm)	Rated current (mA)	Voltage (VDC)	Resistance $\pm 10\%$ @25°C (ohms)	Kinetic power ratings (W)	External Inertia (kg · cm <sup>2</sup> )	Max speed (rpm)	Weight (Kg)
BHB-124A	A. 06. 05. 002	120	1200	24	20	5 min 2800 Continuous 2500	5.6*10 <sup>1</sup>	12000	21.8

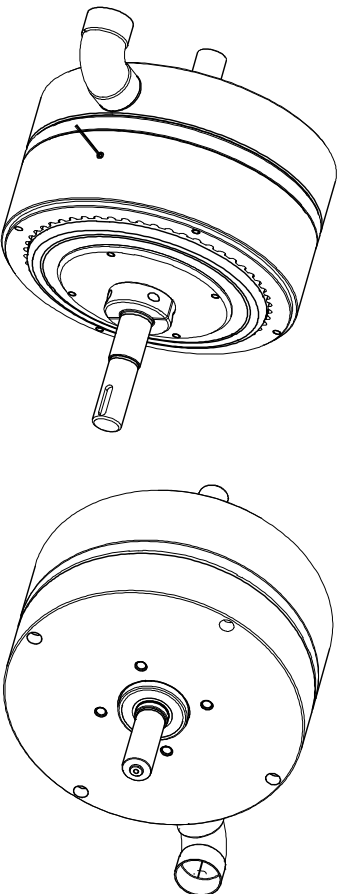
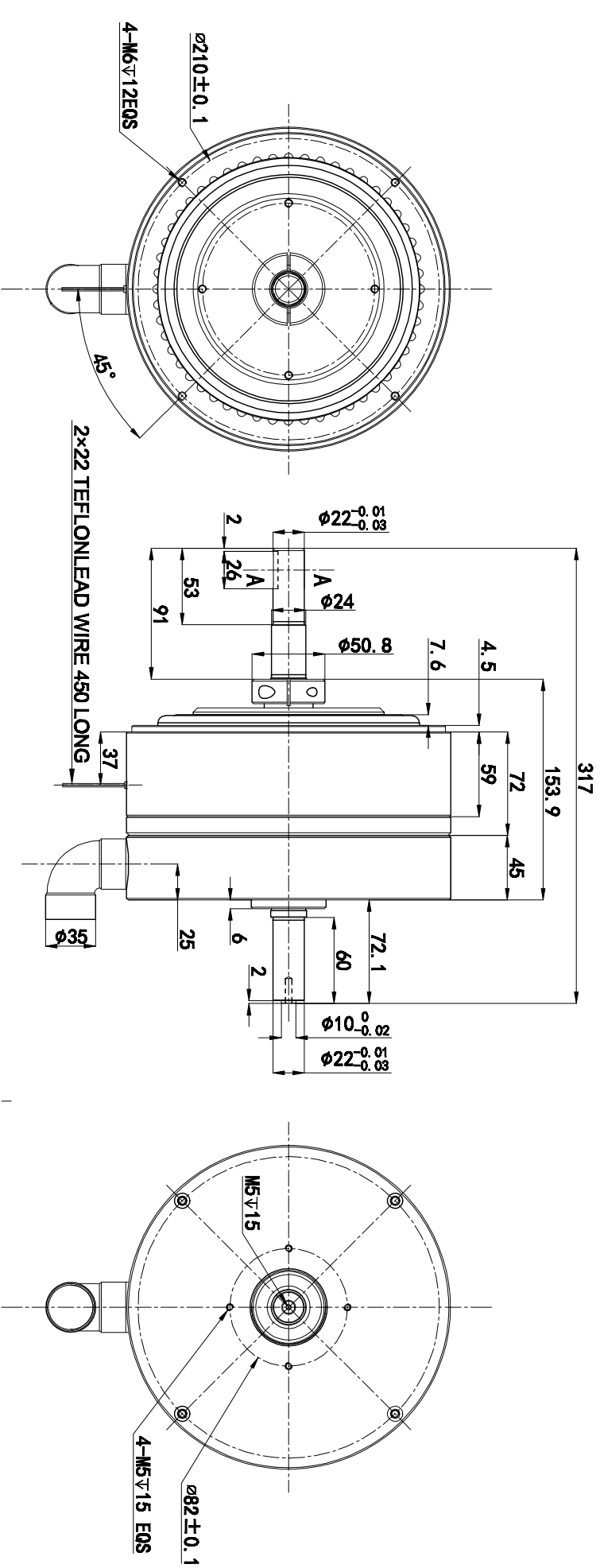

Note: Mounting screw 4-M5 maximum allowable depth 15mm.

Type	BHB-124A	Name	Blower Hysteresis Brakes
Designer		Scale	-
Verifier		Unit	mm
Approver		Version	A0

Valid Magnetics Ltd

The third angle

