

Hysteresis Dynamometer Product Manual

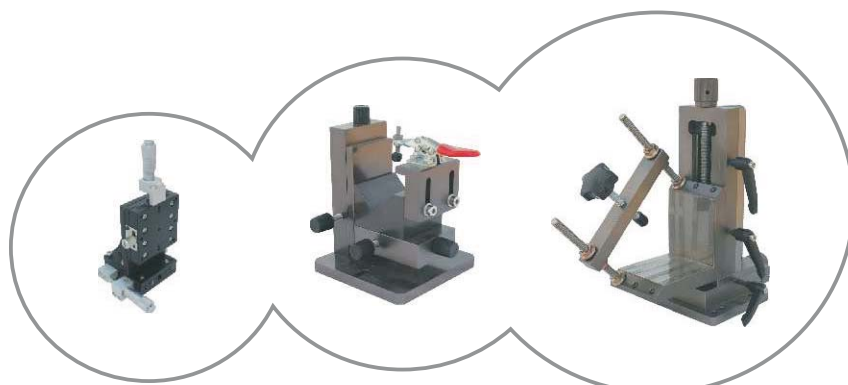

Installation clamps



Precise couplings

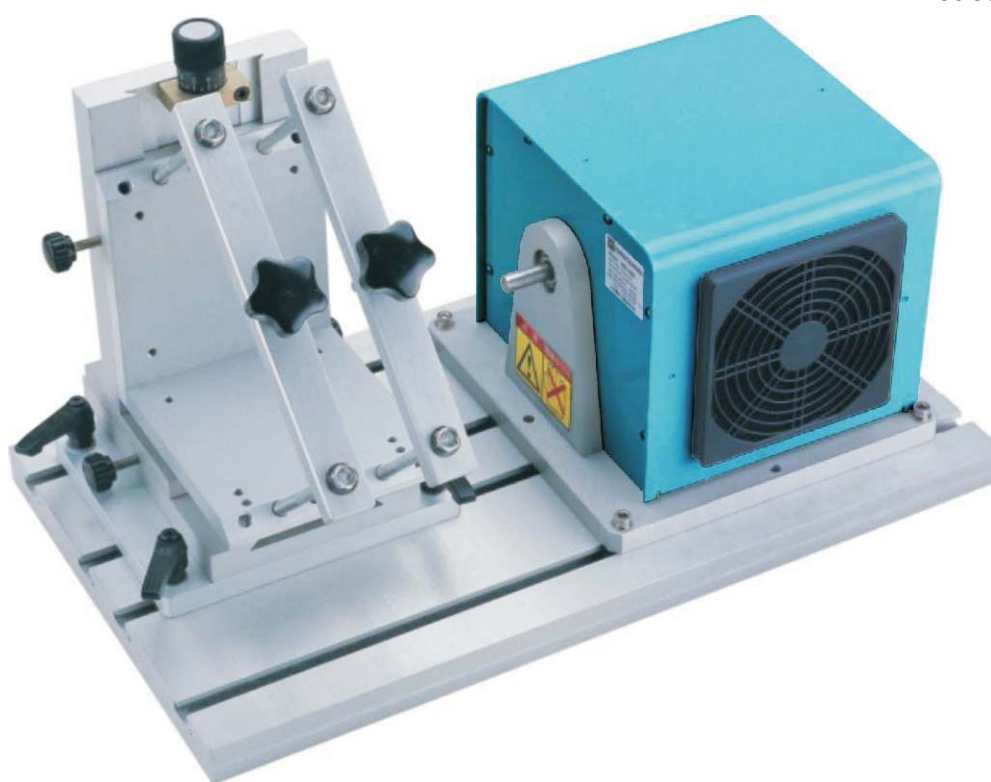

Valid Magnetics Limited



Dynamometer for product introduction

1. Product Overview	P02-03
2. Operation and Maintenance	P04-08
3. Technical reference	P09-13
4. Selection Guide	P14–18

HDC – 101 Controller

1. Connection method	P20
2. Operation	P21
3. Function	P22–23

Appendix

1. The rest parts	P24
2. Packing list	P25
3. Maintenance	P25
4. After-sale service	P25

HYSTERESIS DYNAMOMETER

Product Overview

1.1 Product introduction

Hysteresis Brake Dynamometer is designed for testing with low to middle power appliances, especially high-speed motor testing. It is able to provide a complete measurement of a motor from free-running to rotor-locked because the source of torque generated is not coming from speed. There are three brake-cooling methods for our own designed hysteresis brake dynamometers: HD type: cooling by air fan or convection (no external source); AHD type: cooling by compressed air; BHD type: cooling by dedicated blower. Our hysteresis dynamometers have achieved accuracy ratings of $\pm 1\%$ full scale, depending on size and system configuration. Fine adjustment for optimization can be done with the support of our own invented dynamometer controller. It has high cost/performance ratio with small size and simple operation procedure. Customized or special designed of fixing units, based on the customer requirement is possible.

1.2 Product features

- Hysteresis brake system does not affected by the rotation speed so that it can provide accurate torque loading.
- It can perform the motor test from free rotating to full loading.
- Long or short base plate is optional.
- Customized specification of dynamometer is possible for special torque or speed requirement.
- Standard torque unit: kg.cm/N.m Or g.cm/mN.m.
- Precision: $\pm 1\%$ (Full scale);
- Temperature sensing system to avoid the overheat of equipment.
- Speed range : 0.1 to 100000 rpm. (0.1 to 3000 rpm with encoder)
- The rotator of dynamometer is designed in cup-shaped structure with small inertia. Suitable for different motor speed.
- High precision of testing supported with precise and accurate loading / torque transducer and speed sensor.
- The high sensitivity, stability and load torque test repeatability;
- High resolution and stable digital display of torque and speed values to provide reliable test.
- Simple structure without the depend of accessories. Convenient and easy to be repaired.
- Simple operation: Loading torque can easily be tuned by adjusting the knob from power supply. It can perform the braking and temperature raising test smoothly.
- Single and stabilized DC power supply so that braking / loading torque is convenient to be adjusted
- Optional own designed controller, display instrument, power supply, software, fixing units and accessories can be supplied as a full system for motor testing.

1.3 Application fields

Hysteresis Dynamometers are suitable for testing torque-speed characteristics of kinds of universal motors, series motors, DC permanent magnetic motors, single-phase points in induction motors, shaded pole motors, capacitor start motors, synchronous induction motors and multiphase induction machines. They are widely used to apply for modeling machine, molding tools, hardware, machinery and so on industry,



HYSTERESIS DYNAMOMETER

1.4 The structure principle

Hysteresis dynamometer is consisted of a hysteresis brake installed on the bearing stand, a torque sensor and a speed sensor.

During the test, the tested motor is rotated by the rotor of brake. While the excitation current applies on the brake, the air gap forms a flux field to restrain the brake and thus the tested motor from rotating. The slight variation of brake is sensed by the torque sensor and converted into electrical signal so as the speed which is monitored by the speed sensor. Those values are displayed on the LCD.

Calibration

While the dynamometer is in steady status without loading, and the torque value shown is not zero, tuning the "Zero" potentiometer can calibrate it to set zero. The torque sensor is installed and fixed by elastic clamps with screws on outer stator. A potential difference is generated and amplified by the opamps when there appears an imbalance on the loading electrical bridge. This potential difference is measured and turned into the torque value. Calibration can be done by tuning the "Cal" potentiometer on the rear panel of the dynamometer.

Torque sensor

The amplification part of torque sensor is consisted of a laser calibrated, high precision, low drift opamp IC and other circuits.

Speed Sensor

The speed is converted by the photoelectric sensor into electrical signals, which is composed of an infrared light emitting diode, photodiode and composition in the tail end of the transmission shaft assembly of a grating disc. Infrared light emitting diode is not visible light source, photoelectric diode is a light signal into electrical signal conversion device. Infrared light through the grating disc groove (hole) into the photodiode. Since the luminous grating disc has a high-speed rotation of the light and dark between the diode and a photodiode in the infrared, photoelectric diode impedance change of the conductive when light, photodiode (low impedance), signal voltage is low (about 60mV), on the contrary, when the light is shut off, the signal voltage rise (close to the supply voltage the change of impedance), pulse voltage, speed is converted into pulse signal. Pulse frequency and the transmission shaft speed is proportional to. The actual speed and the grating disc slot number.

Note: The grating wheel must be aligned to match the gap of photoelectric sensor to eliminate the axial deviation of photoelectric sensor which would cause the measuring error.

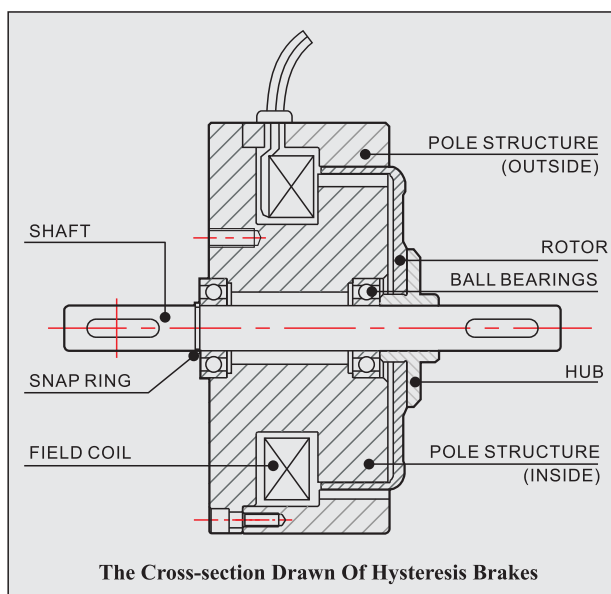



HYSTERESIS DYNAMOMETER



Operation and maintenance

2.1 Safety Precautions



Please take the time to read this page thoroughly before connecting and using your dynamometer. There are two levels of safety precautions: "DANGER" & "ATTENTION"

 DANGER	This symbol shows something about "lead to death or serious injury more likely" when the mistake operation takes place.
 ATTENTION	This symbol shows something about "may resulted in injury or property damage" when the mistake operation takes place.

The following figure shows that

	The symbol means "Don't do it!"
	The symbol means "Have to do it!"

DANGER

	Rules	Consequences if don't obey
	Avoid using product in an environment where it may be exposed to chemicals or corrosive gases.	May cause fire.
	Burnable material can't be taken around with product.	
	Don't use product in strong vibration environment.	May cause electric shock, injury or fire.
	Don't use power line if which steeped with water or oil.	May cause electric shock, breakdown, or damaged.
	Don't place any heavy objects on power line to avoid been damaged.	
	Don't connect wire or operate product with wet hands.	May cause electric shock, injury or fire.
	Don't touch exposed rotating parts of product when operating.	May cause injury.
	Please use it in dry, oil-free, free of dust places.	May cause electric shock, breakdown, damaged or fire.
	Connections should be operated by professional electrician and make sure all of them are corrected.	May cause electric shock.
	Proper grounding is required. Periodically check the insulation of every electrical components.	May cause electric shock, breakdown, or fire.
	Please set up emergency stop circuit outside! Ensure that you can cut off the electricity supply in emergency.	May cause electric shock, breakdown, damaged, injury or fire.
	Have to set up overcurrent protective device, ELCB, and the device to prevent over heating.	May cause electric shock, injury or fire.

HYSTERESIS DYNAMOMETER



ATTENTION

	Rules	Consequences if don't obey
	Don't place heavy objects on product.	May cause breakdown or damaged.
	Don't plug the heat-sink window of product.	May cause electric shock or fire.
	Don't switch on or switch off power supply continually.	May cause breakdown.
	Don't get close to the product if it still start up automatically when the power is recovered after the electric network is out of electricity.	May cause injury.
	Don't transform or disassemble the product by yourself.	May cause electric shock, breakdown, injury or fire.
	The limit about voltage shall be complied with.	May cause electric shock, injury or fire if exceeding the rated voltage.
	Please install the product to correlative equipments after normal operation.	May cause injury.
	Please cut off electricity supply when a fault happens.	May cause fire.
	Please shut down the power switch during the blackout to avoid product starting up automatically when the power is recovered.	Get close to rotating shaft may cause injury when the power is recovered.
	Be sure to cut off the power supply of product if it will not be used for a long time.	May cause injury.
	The testing and maintaining should be completed by the professional staff.	Improper operation may cause electric shock or injury.

HYSTERESIS DYNAMOMETER

2.2 Method of use

(1) Preparation work

The dynamometer must be installed on a rigid and stable table or stand, which is horizontal and fixed on the T-slot plate. A 24V power supply is plugged into the socket on the rear panel of dynamometer. Set zero by the "Zero" button on the rear panel if the measured torque reading is not zero after the power is switched on.

(2) The counterpoise correction

There is a balance loading bar on the dynamometer's shaft end. Face the side of bar with four hanging pins as front (As below diagram). The distance from the center of bar to the end is "L". During the calibration, "manual" mode is switched. Adjust the manual loading knob to its maximum and place the counterpoise (with confirmed and exact weight "G") to the end of bar ("CW" for clockwise and "CCW" for anti-clockwise) until the bar is at equilibrium. Finally, adjust the potentiometer for calibration (located at rear panel of dynamometer) until the shown torque value is consistent with the calculated value "M" by the following equation:

$$M(\text{N.m}) = G \cdot L \cdot 10^{-2} \text{ or } M(\text{kg.cm}) = G \cdot L.$$

, where G is weight of counterpoise in kg, L is the distance from center to the end of the bar in cm and G is the constant 9.81

The counterpoise correction diagram

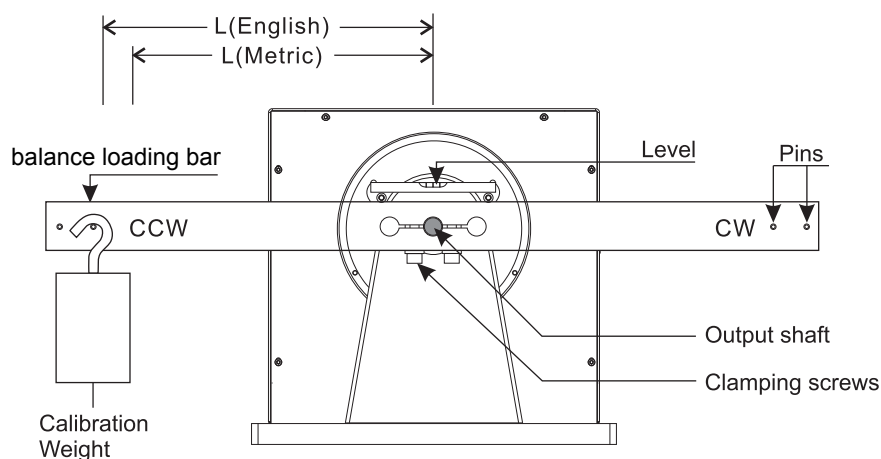

● HD-101/201 Torque calibration bar

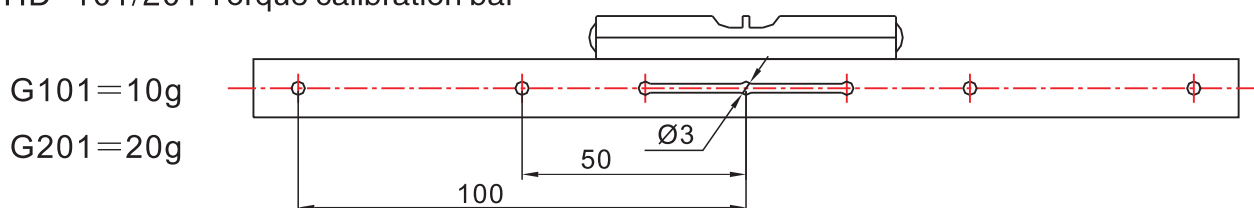

● HD-301 Torque calibration bar

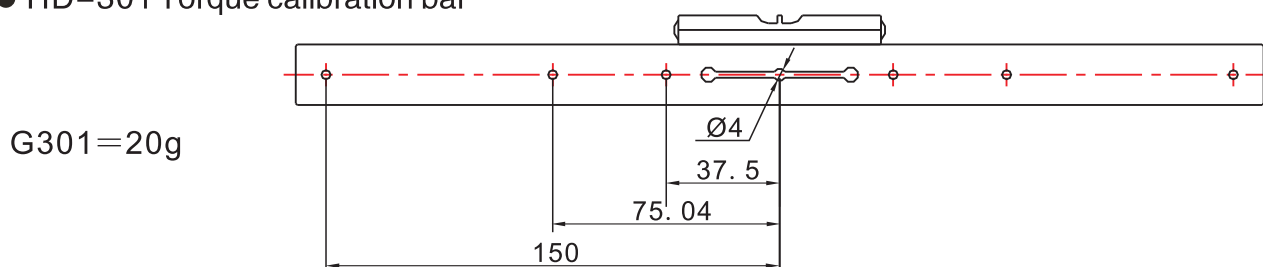

HYSTERESIS DYNAMOMETER

● HD-501 Torque calibration bar

G501=50g

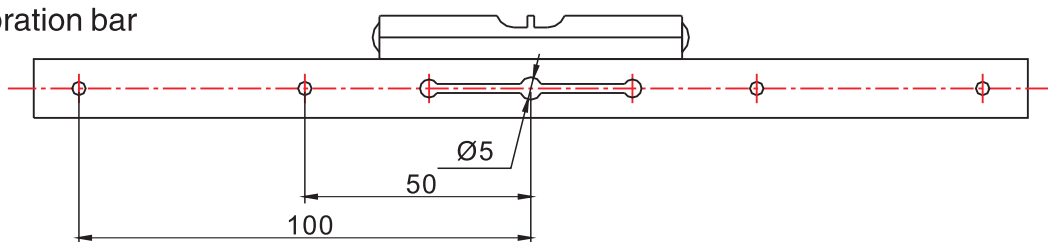

● HD-102/202 Torque calibration bar

G102=50g

G202=100g

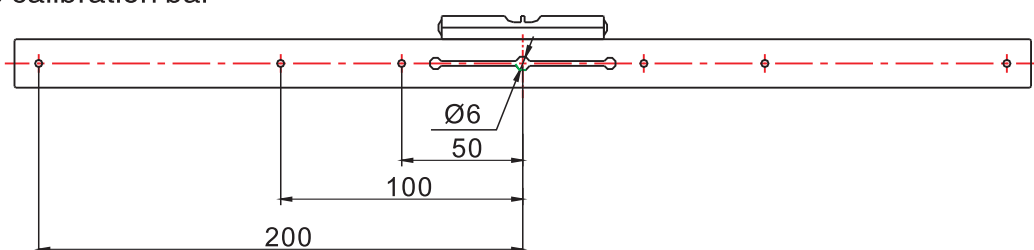

● HD-302 Torque calibration bar

G302=200g

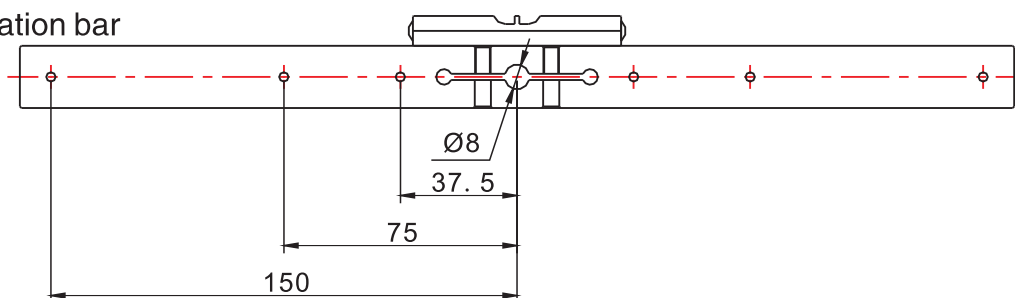

● HD-502 Torque calibration bar

G502=200g

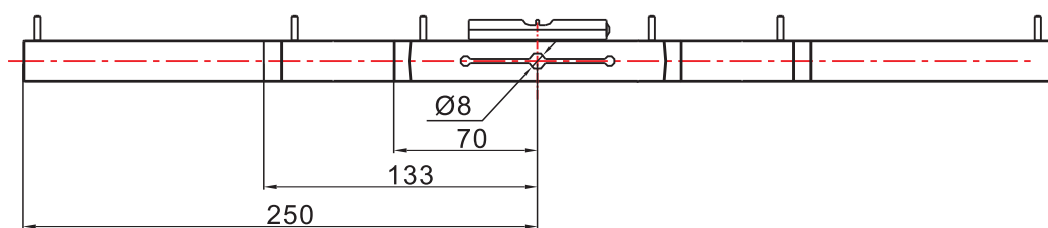

● HD-103 Torque calibration bar

G103=500g

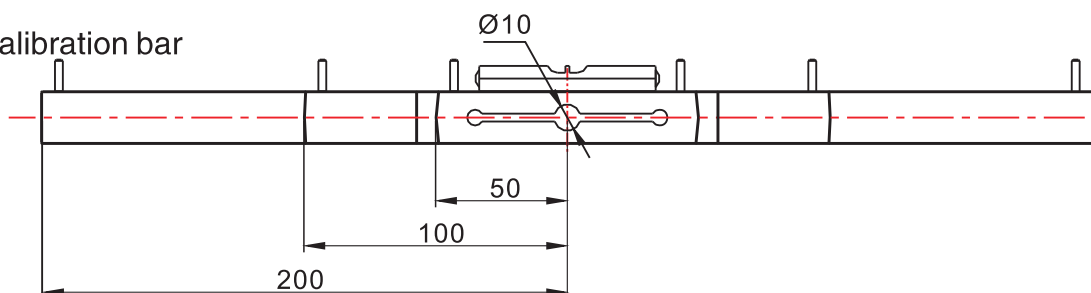

HYSTERESIS DYNAMOMETER

- HD-203 Torque calibration bar

G203=1kg

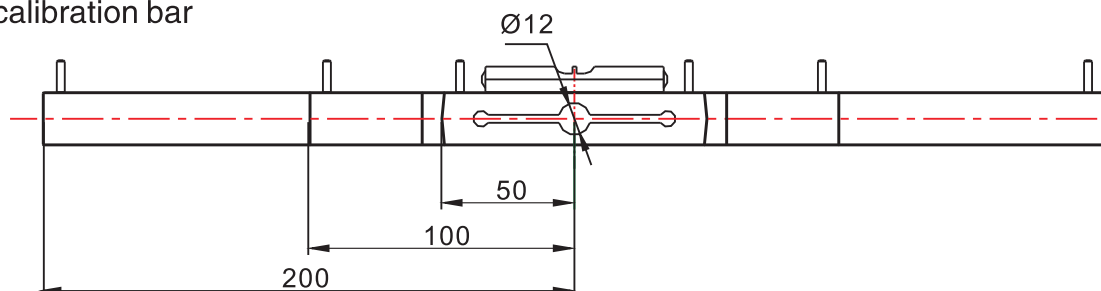

- HD-303/603 Torque calibration bar

G303=1kg

G603=2kg

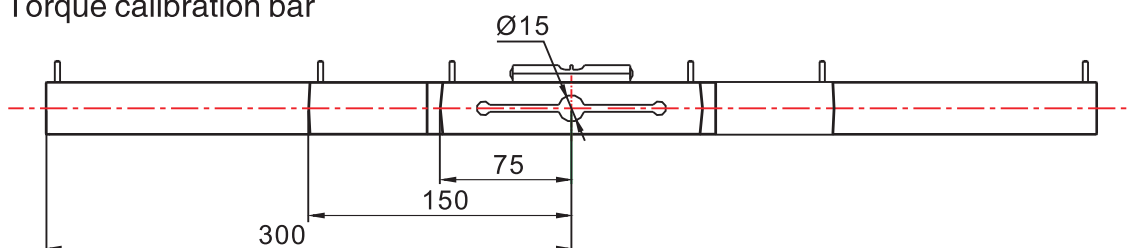

- HD-503 Torque calibration bar

G503=2kg

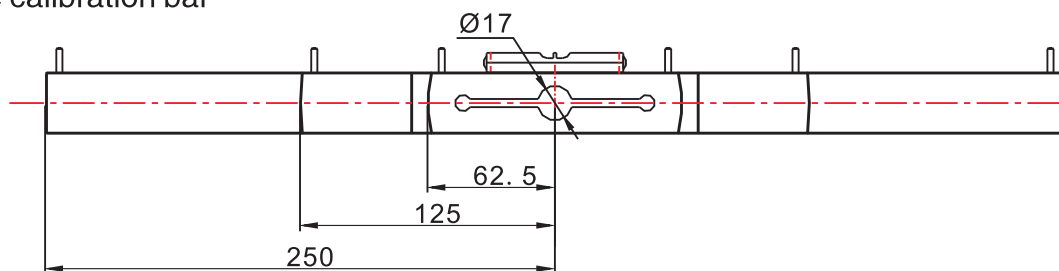

- HD-144/284 Torque calibration bar

G144=5kg/2.5kg

G284=10kg/5kg

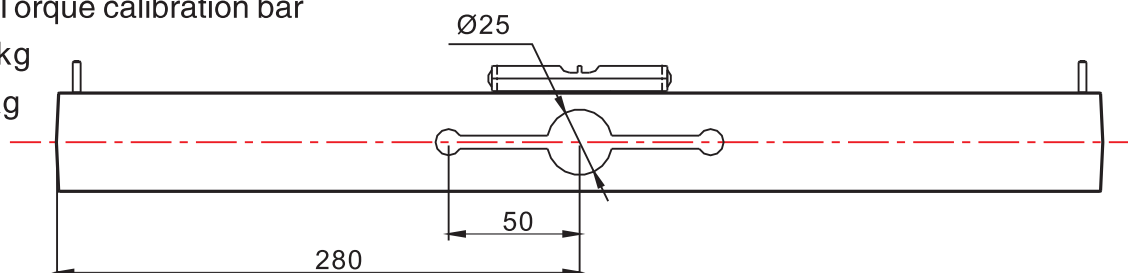

(3) Motor mounting

- Fix the metal coupling on the shaft of dynamometer with screws at the same side of cross section of the shaft. The motor is fixed on another metal coupling. (Note: Outside diameter, pin diameter and the pin to pin distance have to match with the couplings of rotating shaft of the dynamometer.)
- Specialized clippings or fixing tools are needed to be installed on the plate of dynamometer for different motors depending on its shape and structure.
- Concave blade is used to test and confirm that the motor shaft, dynamometer rotating shaft and coaxial axis line in the same axis. Use the blade as a tool to check along the axis of two couplings with four directions (up, down, left, right) to see if they are concentric.
- Tighten the lock bolt of clamps.
- Repeat the checking steps to confirm there is no deviation in axis after tightening the clamps. Finally, fix the clamps on the plate of dynamometer.

HYSTERESIS DYNAMOMETER

2.3 The shape structure

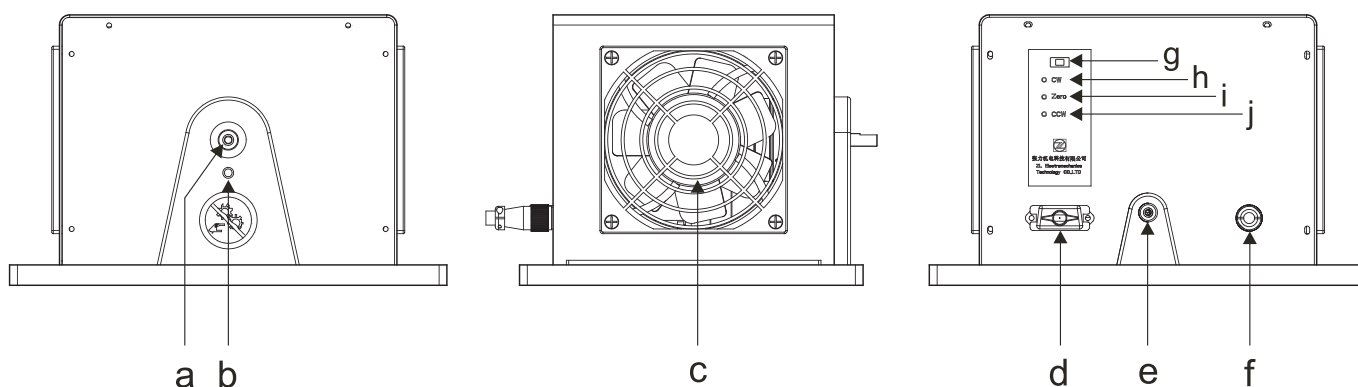

Note: The dynamometer structures have slight differences among the models but the main functions and components are same. The above one is an example for reference.

- a** Output shaft
- b** Transportation bolt: Lock the bolt for avoiding the damage of sensor in long-distance transportation. (For dynamometer with 30kg.cm torque above only)
- c** Cooling fan. (Note: dynamometers with 30kg.cm torque above do not have fan but holes with the same function.)
- d** Data port to controller. (Note: make sure to plug in or out when the power is switched off to avoid damage.)
- e** Cooling air input. High pressure gas is connected to this input port for AHD series, whereas air blower is connected for BHD series. Input port is omitted for HD series.
- f** Connection to "brake / fan" port of controller.
- g** Speed encoder: Optional of 60/600 bit encoder or 60/6000 bit encoder for dial switch. System default is 60, which is fixed.
- h** CW CAL adjusting port (for clockwise adjustment). Used when the torque value is different to the actual value. Not suggested to use under normal situation.
- i** Zero port: set zero when the shown torque value is not zero under no loading condition.
- j** CCW CAL adjusting port (for anti-clockwise adjustment). Used when the torque value is different to the actual value. Not suggested to use under normal situation.

HYSTERESIS DYNAMOMETER

Technical reference

Specifications

Model	kg·cm Minimum torque at rated current	Kinetic power(5 minutes)			Kinetic power(Continuous)			(rpm) Max speed	Cooling mode
		Natural Convection	With air supply	With blower	Natural Convection	With air supply	With blower		
HD convection air cooling type hysteresis dynamometer									
HD-200	0.02	10	—	—	5	—	—	100000	Fan
HD-500	0.05	20	—	—	6	—	—	100000	Fan
HD-101	0.1	35	—	—	8	—	—	30000	Fan
HD-201	0.2	35	—	—	8	—	—	30000	Fan
HD-301	0.3	50	—	—	12	—	—	30000	Fan
HD-501	0.5	50	—	—	12	—	—	30000	Fan
HD-102	1	90	—	—	25	—	—	25000	Fan
HD-202	2	90	—	—	25	—	—	25000	Fan
HD-302	3	250	—	—	65	—	—	25000	Fan
HD-502	5	250	—	—	65	—	—	25000	Fan
HD-103	10	400	—	—	80	—	—	25000	Fan
HD-203	20	580	—	—	120	—	—	25000	Fan
HD-303	30	700	—	—	150	—	—	25000	Fan
HD-503	50	1000	—	—	200	—	—	25000	Natural Convection
HD-603	60	1400	—	—	300	—	—	25000	Natural Convection
HD-144	140	2000	—	—	700	—	—	12000	Natural Convection
HD-284	280	3800	—	—	1300	—	—	10000	Natural Convection
HD-504	500	1000	—	—	200	—	—	1000	Natural Convection
AHD compressed air cooling type hysteresis dynamometer									
AHD-301	0.3	50	80	—	12	20	—	25000	Compressed air
AHD-501	0.5	50	80	—	12	20	—	25000	Compressed air
AHD-102	1	90	200	—	25	80	—	25000	Compressed air
AHD-202	2	90	200	—	25	80	—	25000	Compressed air
AHD-302	3	250	400	—	65	120	—	25000	Compressed air
AHD-502	5	250	400	—	65	120	—	25000	Compressed air
AHD-103	10	400	800	—	80	350	—	25000	Compressed air
AHD-203	20	580	1000	—	120	500	—	25000	Compressed air
AHD-303	30	700	1300	—	150	800	—	25000	Compressed air
AHD-503	50	1000	1500	—	200	1200	—	25000	Compressed air
AHD-603	60	1400	2500	—	300	1500	—	25000	Compressed air
AHD-144	140	2000	2800	—	700	1800	—	12000	Compressed air
AHD-284	280	3800	5000	—	1300	2800	—	10000	Compressed air
AHD-504	500	1000	1500	—	200	1200	—	1000	Compressed air
BHD air blower cooling type hysteresis dynamometer									
BHD-303	30	700	—	1500	150	—	900	25000	Blower
BHD-503	50	1000	—	2000	200	—	1800	25000	Blower
BHD-603	60	1400	—	3200	300	—	2800	25000	Blower
BHD-144	140	2000	—	3500	700	—	3000	12000	Blower
BHD-284	280	3800	—	7000	1300	—	5500	10000	Blower
BHD-504	500	1000	—	2000	200	—	1800	1000	Blower

Note:

Clean and dry air supply equipment is needed and provided by customer.
Addition of water and oil repellent device, and air pressure reducing valve is strongly recommended to be provided and installed by customer.

HYSTERESIS DYNAMOMETER

Outline parameters for hysteresis dynamometer with short plate

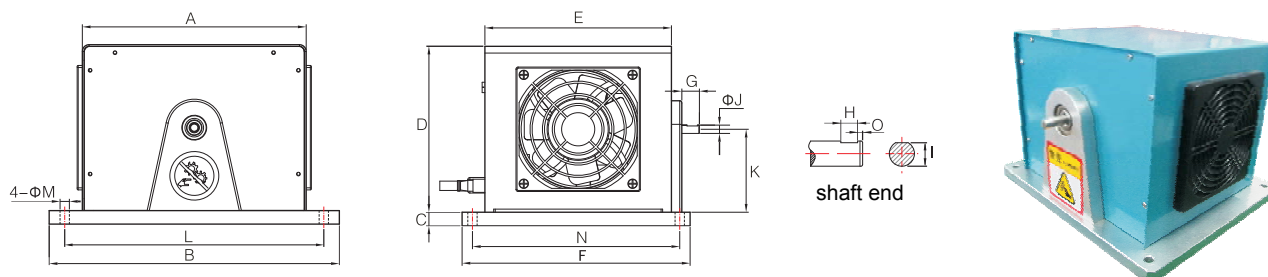

Specifications

(Unit : mm)

MODEL	A	B	C	D	E	F	G	H	I	ΦJ	K	L	ΦM	N	O
HD-301	216	280	13	160	180	220	17	6	3.7	4	80	250	9	200	1.5
HD-501	216	280	13	160	180	220	17	8	4.5	5	80	250	9	200	2
HD-102	216	280	13	160	180	220	17	8	5.2	6	80	250	9	200	2
HD-202	216	280	13	160	180	220	17	8	5.2	6	80	250	9	200	2
HD-302	216	280	13	160	180	220	17	10	7.2	8	80	250	9	200	2
HD-502	216	280	13	160	180	220	17	10	7.2	8	80	250	9	200	2
HD-103	226	280	13	180	200	241	22	10	9	10	100	250	9	216	2
HD-203	226	280	13	180	200	241	22	12	11	12	100	250	9	216	3

Outline parameters for hysteresis dynamometer with long plate

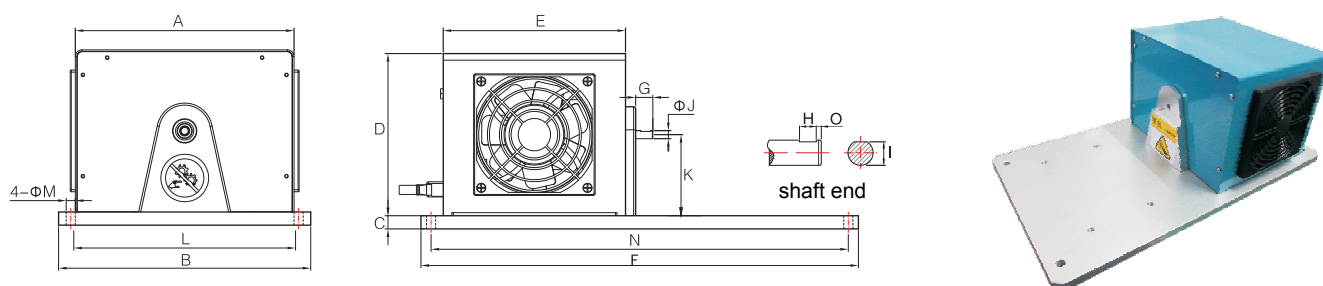

Specifications

(Unit : mm)

MODEL	A	B	C	D	E	F	G	H	I	ΦJ	K	L	ΦM	N	O
HD-101	216	249	12	160	180	432	14.5	3	2.7	3	80	200	9	400	1.5
HD-201	216	249	12	160	180	432	14.5	3	2.7	3	80	200	9	400	1.5
HD-301	216	249	13	160	180	432	17	6	3.7	4	80	200	9	400	1.5
HD-501	216	249	13	160	180	432	17	8	4.5	5	80	200	9	400	2
HD-102	216	249	13	160	180	432	17	8	5.2	6	80	200	9	400	2
HD-202	216	249	13	160	180	432	17	8	5.2	6	80	200	9	400	2
HD-302	216	249	13	160	180	432	17	8	7.2	6	80	200	9	400	2
HD-502	216	249	13	160	180	432	17	8	7.2	6	80	200	9	400	2
HD-103	226	249	13	180	200	500	22	10	9	10	100	225	9	483	2

HYSTERESIS DYNAMOMETER

AHD compressed air cooling type hysteresis dynamometer



Note: The dimensions of HD and AHD series are identical but there is a high pressure input port (shown in the red dashed lines in left photo). Please read the P01 for models of HD series for the size.

BHD air blower cooling type hysteresis dynamometer



Note: The dimensions of HD and BHD series are identical but there is a air blower input port (shown in the red dashed lines in left photo). Please read the P01 for models of HD series for the size.

HD-303/AHD-303/BHD-303 Outline dimension drawing

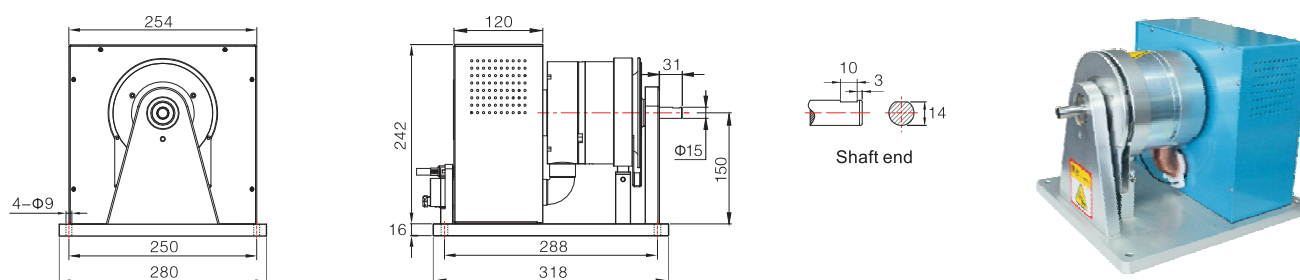

HD-503/AHD-503/BHD-503 Outline dimension drawing

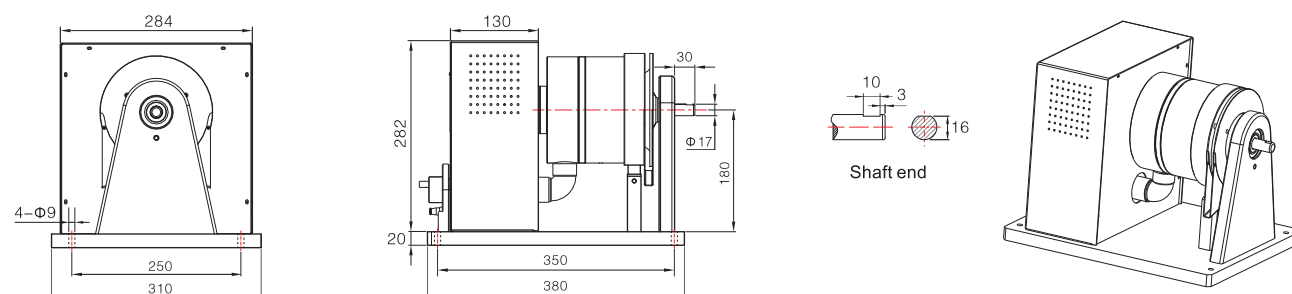

HYSTERESIS DYNAMOMETER

HD-603/AHD-603/BHD-603 Outline dimension drawing

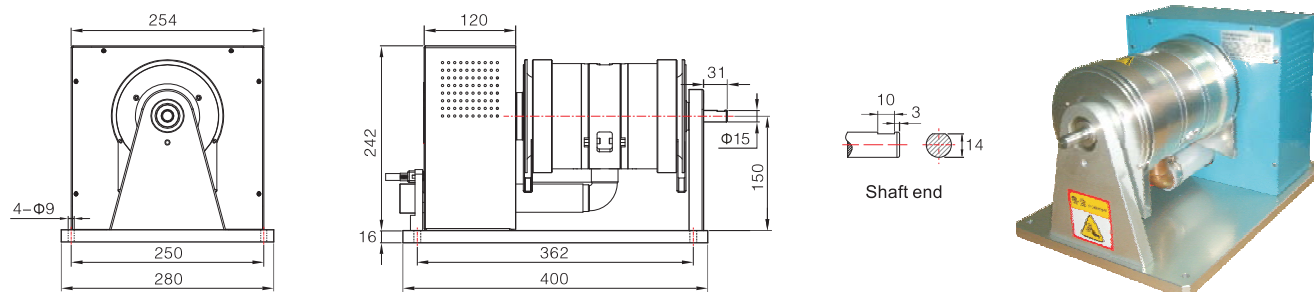

HD-504/AHD-504/BHD-504 Outline dimension drawing

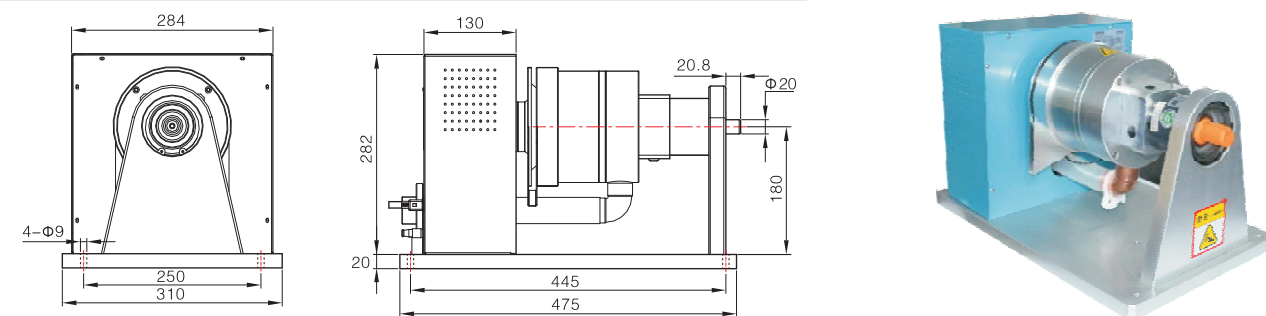

HD-144/AHD-144/BHD-144 Outline dimension drawing

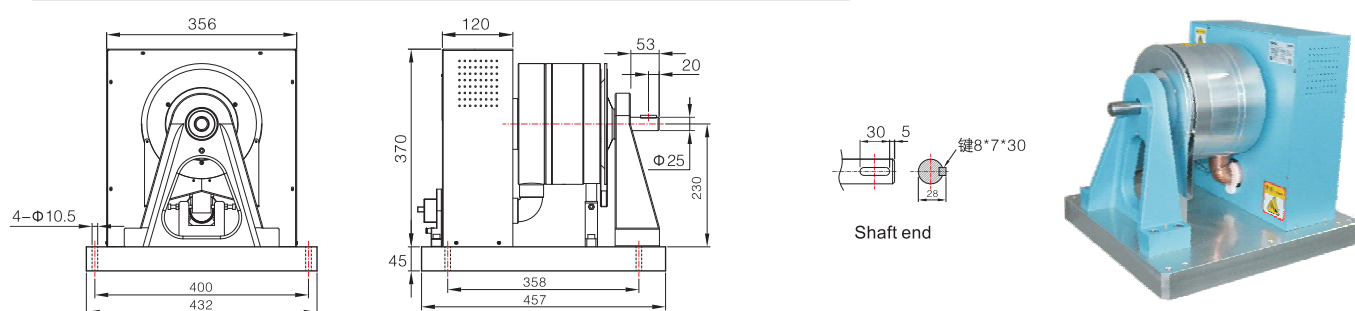

HD-284/AHD-284/BHD-284 Outline dimension drawing

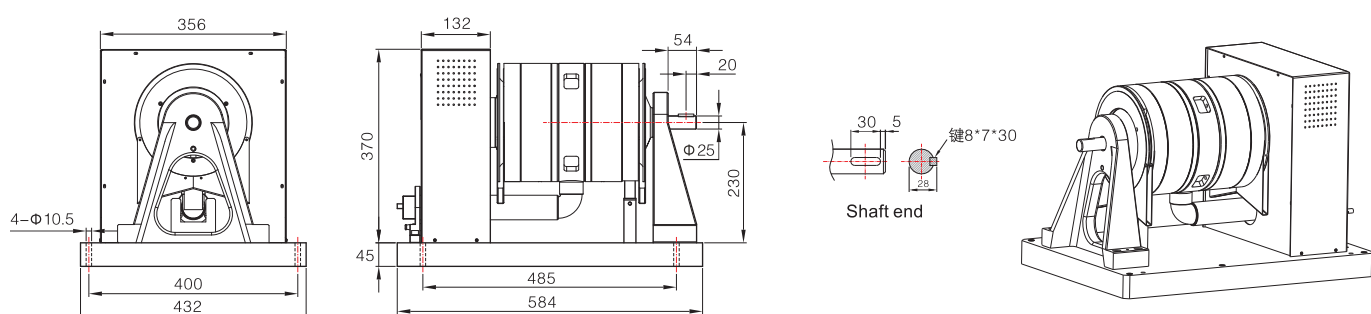

HYSTERESIS DYNAMOMETER

Selection Guide

Our hysteresis dynamometers cover a wide range of power measurement. The following factors have to be taken into account to choose the suitable one.

The rated parameters

- Maximum torque(T)

The first consideration of choosing dynamometer is the maximum torque.

Hysteresis dynamometer can provide torque output at any speed, including low speed or in steady. Besides the rated torque, every testing point of torque including collapsing torque and stalled torque must be considered.

- Maximum speed(N)

Maximum speed stated here is not related to the torque or power. It is the maximum speed that the hysteresis dynamometer can perform safely under no or light loading condition. Usually, the dynamometer is not able to output the maximum torque at it's maximum speed.

- The maximum rated power(P)

Maximum rated power refers to the maximum capability of the dynamometer to absorb and dissipate heat generated when applying a braking load to the motor under test. This power is expressed as (P) in the below formulas:

$$\text{SI : } P(W) = T(N.m) \times n(\text{rpm}) \times (1.047 \times 10^{-1})$$

$$\text{Metric: } P(W) = T(\text{kg.cm}) \times n(\text{rpm}) \times (1.027 \times 10^{-2})$$

,where T is torque applied to the motor under test and n is the speed of motor.

The ability to dissipate heat of dynamometer determines the time of a loading can be applied. Therefore, the maximum power ratings given are based on continuous operation under load, and a maximum of 5 minutes under load.

To safely dissipate heat and avoid the damage or failure of dynamometer, maximum power rating is the most important consideration in selecting a dynamometer.

Specifications and dimensions

For the specification of dynamometer, please refer to the Chapter 3.

Power curve

The power absorption curves represent the maximum power or heat that the dynamometer can dissipate over time.

Schematic diagram of the power curve

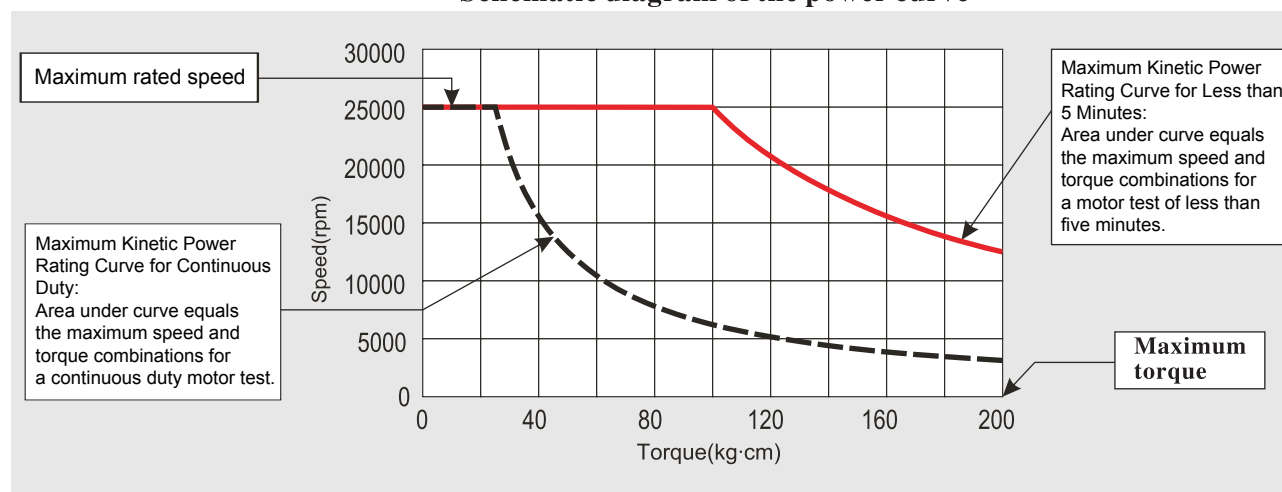

HYSTERESIS DYNAMOMETER

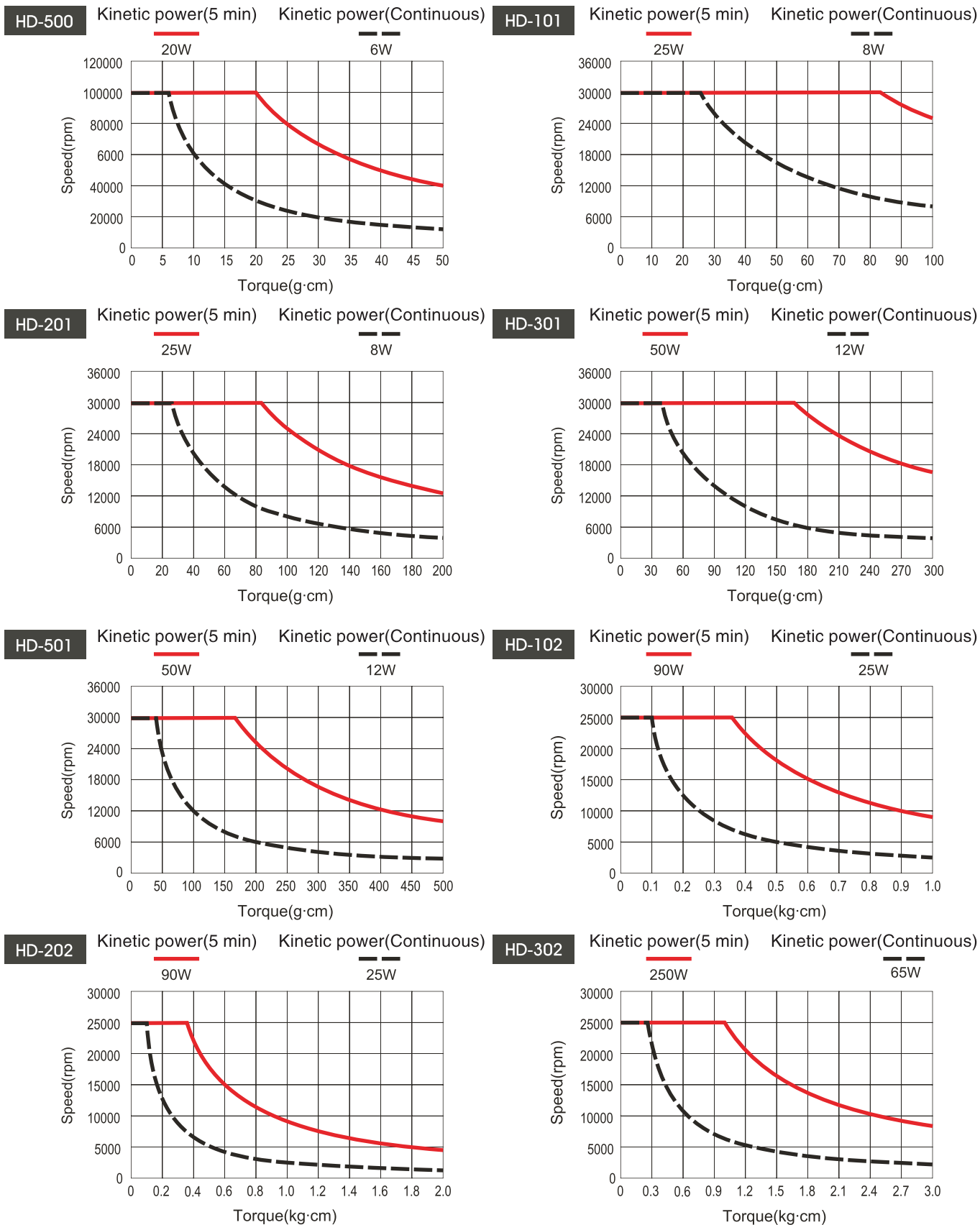

HYSTERESIS DYNAMOMETER

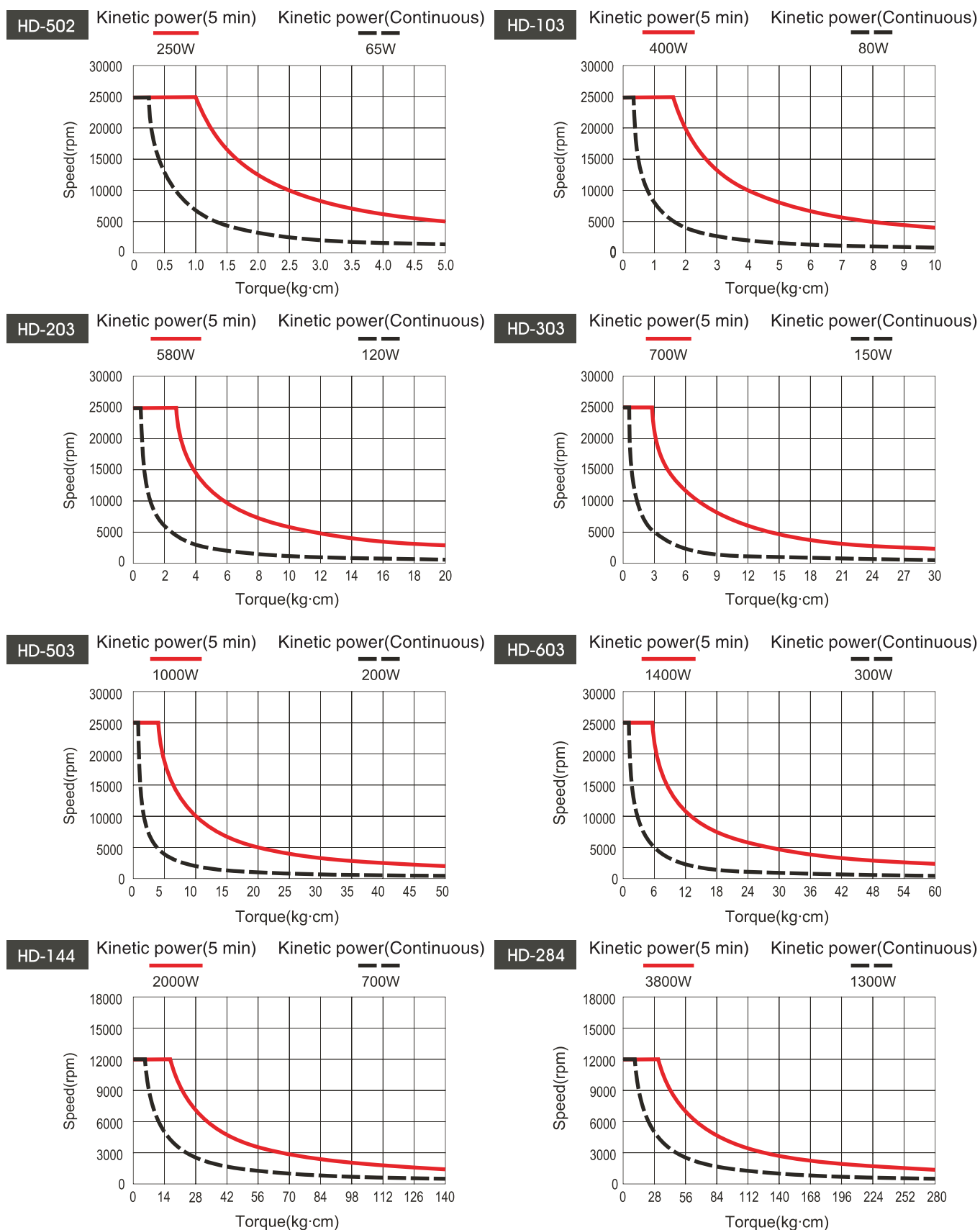

HYSTERESIS DYNAMOMETER

The following curves are measured under the input of external cooling air. Please refer to the HD series for natural cooling.

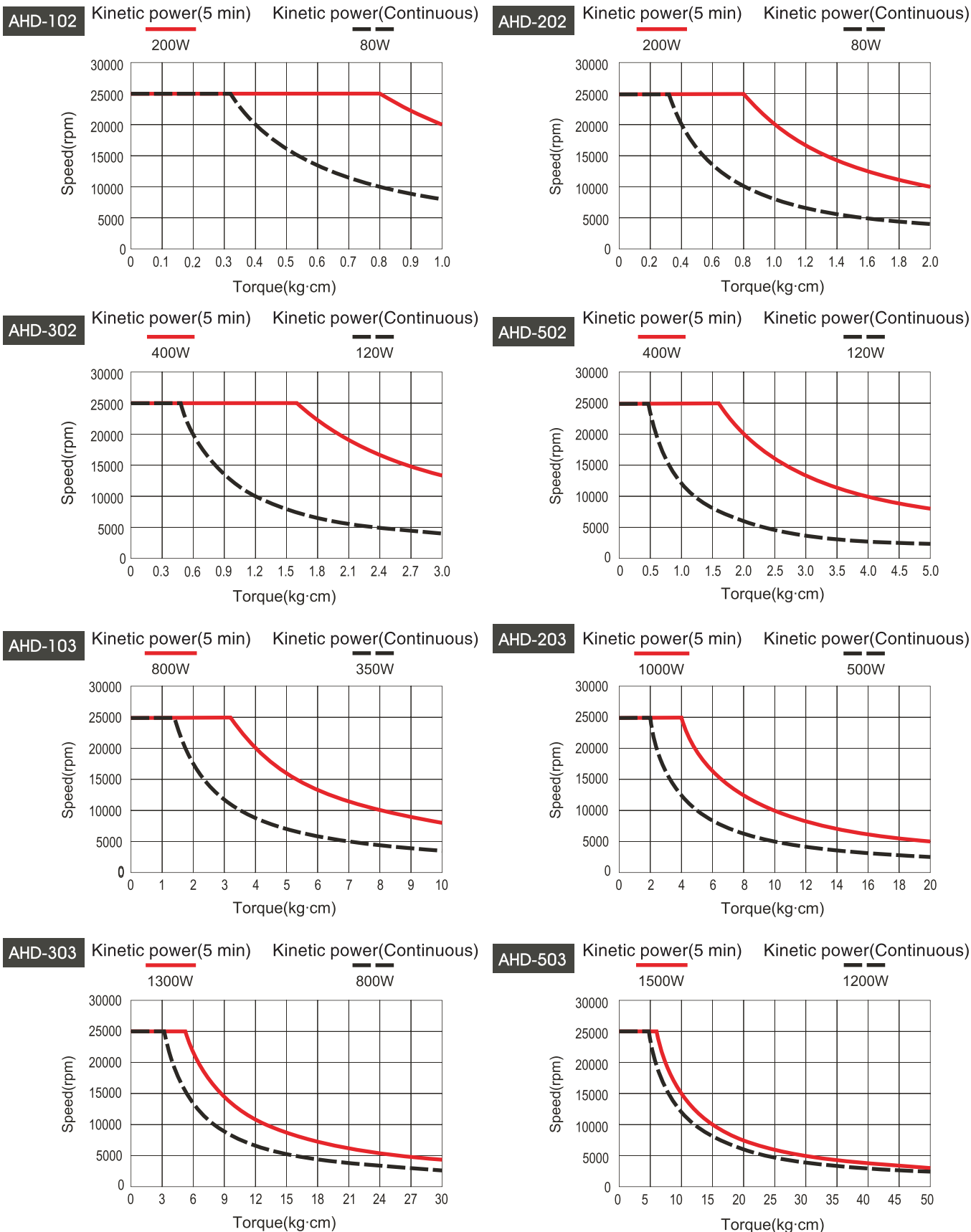

HYSTERESIS DYNAMOMETER

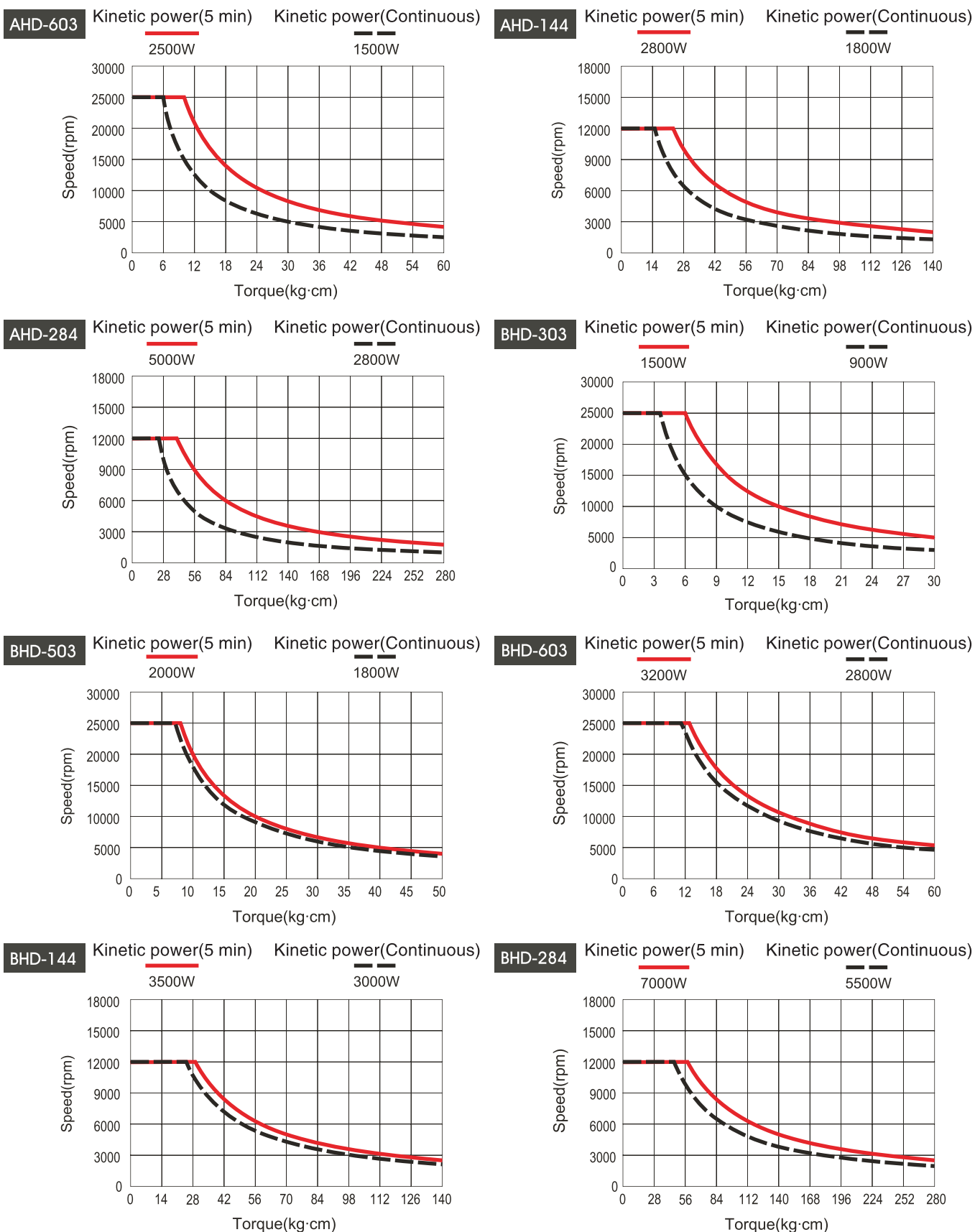

HDC-1010 Controller



HYSTERESIS DYNAMOMETER

Connection method

Computer connection

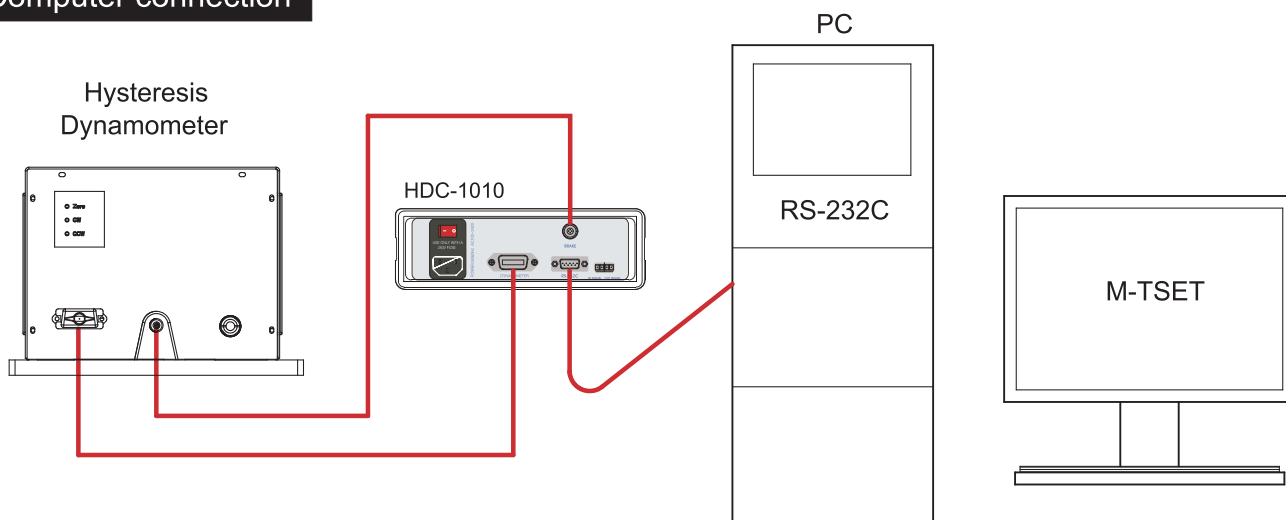

- Tested data including torque, speed and power output value varies time can be stored and connected to the computer.

The alarm

HDC-1010 CONTROLLER

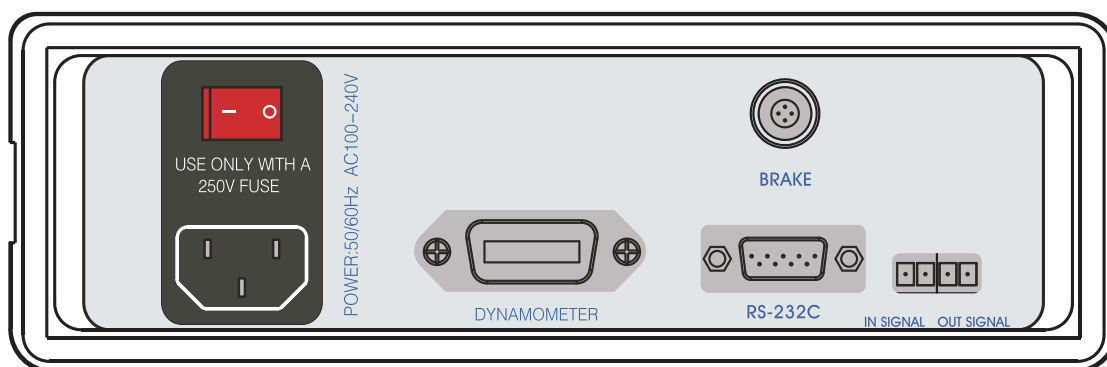

- The alarm signal port can be connected to the alarm, in closed loop with alarm function.

HYSTERESIS DYNAMOMETER

The appearance of the

The front panel

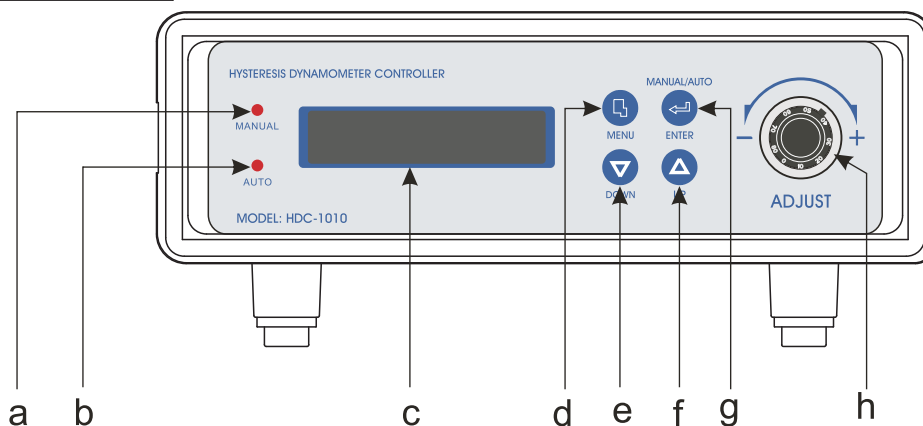

- a** Manual.
- b** Auto.
- c** Display, showing torque , speed and power value.
- d** Menu.
- e** Down.
- f** Up.
- g** Enter/Manual/Auto.
- h** Loading in manual adjustment.

The rear panel

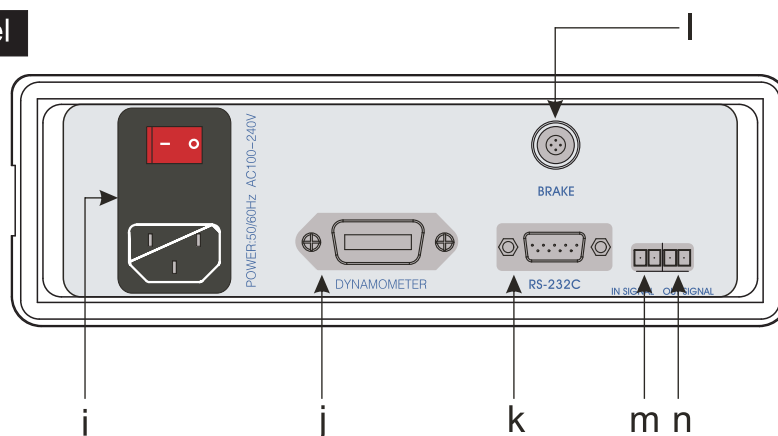

- i** The power input socket: 50/60Hz AC100-240V.
- j** The AC dynamometer data port.
- k** The computer port.
- l** Plug to dynamometer
- m** Closed loop signal switch port.
- n** Alarm signal port.

HYSTERESIS DYNAMOMETER

Menu operation

3.1 LCD Display

Boot into operation mode, with the below display:

T: Torque unit: kg·cm / N·m .

S: Speed units: r/min.

P: A unit of power: W .

t: Temperature unit: °C .

It is a two lines display and please press "UP" and "DOWN" key to switch among lines for reading more data.

3.2 The Menu

Switch on the controller will start the operation mode. Press "Menu" button with 2 seconds to enter the menu. In the sub-menu: ">" stands for the current option, press "UP" and "DOWN" to elect the required option, and press "Enter" to do the adjustment. Press "UP" and "DOWN" buttons to adjust the parameters and press "Enter" to confirm and then quit to the menu. Press "Menu" for 2 seconds to return to the previous menu or return to the operation menu by a short press of "Menu" button.

1. PresetTorque

To adjust the preset torque value within the range 0 to 5kg.cm . Press "Enter" to set the value and "UP" or "DOWN" to adjust. Press "Enter" to confirm and quit.

2. TestMode

Two testing mode is optional: Single cycle and Multi cycle. In single cycle mode, dynamometer will use "Torque1" and "Time1" preset values to perform the test; In Multi cycle mode, dynamometer will use "Torque1" and "Time1" preset values to perform the test in the first stage, followed by "Torque2" and "Time2" to perform the second stage test. The system will return back to the preset torque status after finishing two stages of the test.

3. Torque1

To test under this torque value (0 to 5kg.cm) in single cycle test or the first stage of test in multi-cycle test.

4. Time1

To test under this time value (0 to 60s/min/ hr) in single cycle test or the first stage of test in multi-cycle test.

5. Torque2

To test under this torque value (0 to 5kg.cm) in second stage of test in multi-cycle test.

6. Time2

To test under this time value (0 to 60s/min/ hr) in second stage of test in multi-cycle test.

7. SwitchTorque

To set the condition for switching torque, with range (0~5kg.cm). When the real time torque value is greater than the preset "switch torque" value, system will switch from the "preset torque value" to the "torque1" or "torque2" value. Note: this function is temporary disable.

8. Temperature

Temperature warning alarm setting (Range from 0 to 150C). When the actual temperature greater or equal to this temperature setting, a warning signal "Temperature is out of range" will appear to flash on and off in the operation menu.

9. PIDStartSpeed

To set the PID starting speed (Range from 0 to 25000 rpm). When the real time speed greater or equal to this speed setting, PID is valid.

HYSTERESIS DYNAMOMETER

10. **PIDStopSpeed**

To set the PID stopping speed (Range from 0 to 25000 rpm). When the real time speed less than this speed setting, PID is invalid and system will return and run at the preset toque.

11. **PIDSetTime**

To set the PID startup time (Range from 0 to 100)

12. **TorqueUnit**

To set the torque unit – kg.cm or N.m

13. **TimeUnit**

To set the time unit – second or minute or hour

14. **ClrMagnetic**

Brake degaussing (Range from 0 to 100). Enter this mode for demagnetization when there is oscillation of brake. A reminder question: "Sure?" will be shown. Press "UP" and "DOWN" button to confirm. Use hand to rotate the brake until the demagnetization process is accomplished.

15. **Accuracy**

Fine tune of the accuracy (Range from 0 to 200%). Press "UP" and "DOWN" button to tune the accuracy during the calibration. Press "Enter" to confirm and back to the operation menu.

16. **MaxTorque**

To set the maximum torque value, (range from 0 to 5 kg.cm) under closed-loop testing mode. The real time torque value reaches this limit will trigger the alarm. Press "Enter" to cancel the alarm alert. Set this value to 5 kg.cm as default to disable this alert function.

17. **MinTorque**

To set the minimum torque value, (Range from 0 to 5 kg.cm) under closed-loop testing mode. The real time torque value below this limit will trigger the alarm. Press "Enter" to cancel the alarm alert. Set this value to 0 kg.cm as default to disable this alert function.

18. **LowerSpeed**

To set the lower limit of speed (Range from 0 to 25000 rpm). Alarm alert will be triggered when the speed is lower than this limit after the motor is loaded. Press "Enter" to cancel the alarm alert. Set this value to 0 rpm as default to disable this alert function.

19. **UpperSpeed**

To set the higher limit of speed (Range from 0 to 25000 rpm). Alarm alert will be triggered when the speed is higher than this limit after the motor is loaded. Press "Enter" to cancel the alarm alert. Set this value to 25000 rpm as default to disable this alert function.

20. **PIDDelayTime**

To set the delay time for signal switching (Range from 0 to 60s) from opened-loop to closed-loop mode.

21. **SpeedAcc**

Adjustment of the speed's precision (Range from 0 to 11000). This option is used for calibration of rotation speed with the help of a high precision speed meter.

HYSTERESIS DYNAMOMETER

The accessories

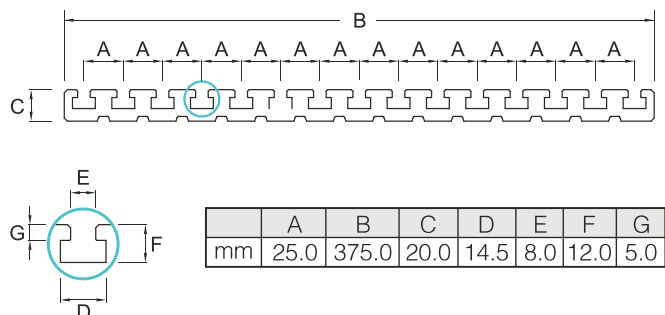

The length of T-slot plate can be customized to your requirement.



T-slot plate



Precision coupling

Motor mounting fixture



HDJ-20



HDJ-40



HDJ-100



Torque calibration bar

HYSTERESIS DYNAMOMETER

Packing list

Please check the following list carefully upon the arrival of the parcel:

No.	ITEMS	QUANTITY	REMARKS
1	Hysteresis Dynamometer	1	Standard
2	Dynamometer controller	1	Standard
3	Power cord	1	Standard
4	Data line	2	Standard
5	The balance bar	1	Standard
6	Product description	1	Standard

Note: Please contact the local distributor as soon as possible if there is any missing parts .

Maintenance

1. Replace the bearings in the driving shaft immediately if there is noise coming out to avoid the possibility of getting stuck of shaft or damage of other machinery parts.
2. Contact our qualified customer service department for maintenance instead of disassembling by your own when the shaft bearings are needed to be placed.
3. Keep clean of the shaft bearings and surrounding area as the dust will raise the possibility of vibration and noise to cause the damage.
4. Handle with care during the installation to avoid the damage by applying high pressure. Beware the damage to shaft bearing by hammer or pressure from the rolling parts.
5. Avoid using hands to touch the bearings directly to cause the rust.
6. Use professional or specialized installation tools only.
7. Use specialized cleansers for machinery parts to the machine and bearings. Ensure there is no contaminant before mounting the bearings in the driving shaft.
8. Few drops of specialized oil or lubricant for precision instrument is added when the outer bearings are removed to be clean.

After-sale service

1. One year of warranty is guaranteed starting from the date of sale.
2. The following situation is not within the scope of warranty:
 - The appearance of machine or parts;
 - Failure caused by abnormal use or misuse;
 - Damage by wrong model is applied or usage exceeding the scope of the listing limit;
 - Damage by improper storage or natural disaster;
 - Damage by disassembly or refit without the authorization from manufactures or distributors

Thank you for your purchase for our product. Please feel free to contact us for any questions



Valid Magnetics Limited

Room 604, Leader Industrial Centre, Fo Tan, Hong Kong

Telephone: 62908202

Email: sales@validmagnetics.com Website: www.validmagnetics.com

HYSTERESIS DYNAMOMETER

3: Back Panel Foot Pin

3.1 14P Plug Pin

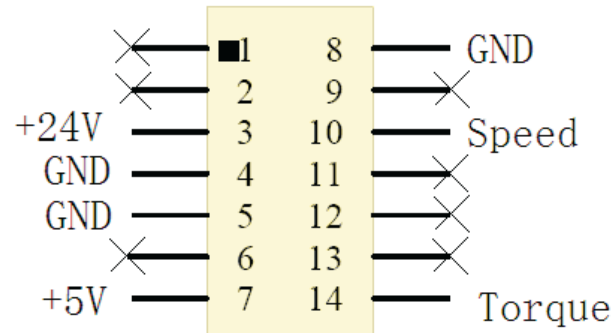

Pin: 1、2、6、9、11、12、13 NC

Pin3: +24V

Pin4/5/8: GND

Pin7 :+5V

Pin10 :RPM Signal, 60 pluses per rotation

Pin14 :Torque Output Signal: 0-10V

3.2 4P Plug Pin

